



KOSMOS series

2-Axis 5-Phase Stepping Motor Driver Box (Internal AC driver type)

TITAN-A II

rev.1.11

Operation Manual

RoHS



Thank you for purchasing the KOHZU Precision Co. product.
Before start using the product, read "Safety Precautions" thoroughly, and use it properly following the warnings and cautions.

Safety Precautions

*To use this product correctly and safely, and to prevent danger to the customers and others, and damage to physical properties, follow cautions in this manual.
*Precautions are categorized into "Warning" and "Caution".

- Warning** When the instruction items are not observed, it can cause death or serious injuries on people.
- Caution** When the instruction items are not observed, it can cause minor injuries and product damage.
- Electric Shock** When the instruction items are not observed, it can cause accident resulting in electric shock, leakage, etc.

*The symbols displayed on the product and the manual are defined as follows.

- Warning** The symbol indicates the contents that should be observed with caution (include warning), because a dangerous state may be generated under the specified condition.

Warning Electric Shock

1. When using on devices that can affect lives and properties (Nuclear control, medical devices, vehicles, railways, aviation, combustion apparatus, recreational equipment, safety devices, etc.), apply a double safety device.
It can cause fire, accident affecting human lives, and damage on properties.
2. Installation, connection, driving, operation, inspection, and troubleshooting diagnostic work should be conducted by personnel who has adequate specialized knowledge.
It can cause fire, electric shock, and injuries.
3. When installing, perform individual grounding using a grounding wire with AWG No. 18 (0.75mm²) or more.
It may cause electric shock.
4. When grounding the product, apply power outage measures.
It can cause injuries and damage on the device from lowered holding torque.
5. Do not use in the place where there is danger for explosion and corrosion, and water, near inflammable gas and materials, in the place with heavy vibrations, and outdoors.
It can cause fire, electric shock, and injuries.
6. Do not touch inside the product and connection terminals immediately after shutting down the power (within 30 seconds).
It can cause electric shock.
7. Do not insert fingers and objects into the opening on the product.
It can cause fire, electric shock, and injuries.
8. Do not disassemble and customize the product. Please contact us for inspection and repair.
It can cause fire, electric shock, and damage on the product.
9. Use an insulated type screwdriver for the volume switch in the product.
It can cause electric shock.
10. Apply insulation treatment not to expose the conductor when connecting a wire to the connector, because high voltage is applied to the connection part.

Caution Electric Shock

1. Do not move, install, and inspect while the power is ON.
It can cause electric shock.
 2. The power input voltage should maintain the rating range, and use a wire with AWG No. 18 (0.75mm²) or more.
It can cause fire and electric shock.
 3. Perform connection according to the connection diagram, and check if the connection is correct before turning the power ON.
It can cause fire, electric shock, and damage on the product.
 4. Install the current breaker at power connection.
It can cause fire.
 5. Shutdown the power promptly when a power outage occurs.
When a power outage is restored, the product suddenly operates causing damage on the device and injuries.
 6. During operation or after stopping, be cautious when touching the product for a certain period.
It can cause damage on the device and injuries.
 7. Emergency stop should be always available during operation.
It can cause damage on the device and injuries.
 8. When inputting the power, apply only after checking the control input signal of the product.
When the input signal is ON, it can cause injuries and damage on the device, because it operates at the same time when the power is applied.
 9. Do not turn the Hold Off signal input ON while maintaining the vertical direction position.
Because the falling phenomenon from lowered motor holding power is generated, it can cause injuries and damage on the device.
 10. After turning the power OFF, if it is necessary to maintain the vertical direction position, install a safety device separately.
Because the falling phenomenon from lowered motor holding power is generated, it can cause injuries and damage on the device.
 11. When moving the motor rotation axis with hands (manual position setting, etc.), perform after checking the Hold Off signal input.
It can cause injuries from unexpected product operation.
 12. When fault is found, conduct emergency stop promptly.
It can cause fire and injuries.
 13. Do not touch the terminals during insulation resistance measurement and a withstand voltage test.
It can cause electric shock.
 14. Do not use exceeding the specifications/rating of the product.
It can cause electric shock, injuries and damage on the device.
 15. When cleaning, do not use water and detergents, but use dry towels.
It can cause electric shock and fire.
 16. When discarding the product, treat it as industrial waste.
 17. Use a 5-phase stepping motor specified on the motor output terminal.
It can cause damage on the device and fire.
- *The specifications, outside dimensions, etc. described in this instruction manual may be changed without prior notice for product improvement.

Specifications/Rating

Model	TITAN-A II	
Product	2-Axis 5-Phase Stepping Motor Driver Box (Internal AC driver)	
Input power	AC90 to 240V, 50/60Hz	
Power output (AC OUT) (1)	AC90 to 240V, MAX1A	
Consumption power	430VA MAX	
Ambient operating temperature	0 to 40°C	
Ambient operating humidity	30 to 85% (there should be no dew condensation)	
Withstand voltage	AC1500V (Between line-FG, one minute)	
Main body weight	3.8kg	
Power output for sensor	+24V, 0.5A MAX	
Internal Driver	MD-551E (x 2)	
Driving current	0.35 to 1.48A/Phase	
Excitation method	Bipolar constant current, new pentagon connection	
Number of divisions	1,2,4,5,8,10,16,20,25,40,50,80,100,125,200,250 division	
CW/CCW Input pulse	Pulse width Pulse interval	0.5 μ sec or more (Duty 50% or less)
	Startup time Fall time	1 μ sec or less
	Voltage	[H]: 4 to 8VDC, [L]: -8 to 0.5VDC *Equals to [H]: The photocoupler in the main body's circuit ON, [L]: The photocoupler in the main body's circuit OFF. It should be the same in the following description.
	Current	8 to 20mA
	Frequency	500kpps or less

*(1) Power supplied from the AC IN inlet is output from the AC OUT outlet.
-Use as the power supply for the host controller of TITAN (ARIES, LYNX, etc.).

Do not supply power from TITAN to TITAN, or to a device that consumption current is 1A or more.

-When the power switch is turned OFF, the power from the AC OUT also becomes OFF.

Outside Dimensions/Accessories

Accessories list

Product name	Usage, Specification	QTY
AC code (Grey)	2m, 7A, AC125V (For AC IN)	1
AC code (Black)	0.5m, 10A, AC250V (For AC OUT)	1
Terminal conversion on plug	3 terminals → 2 terminals conversion 15A, AC125V	1

The AC code (grey) do not support AC200V. When using AC200V for AC IN, prepare by the customers.

The AC code (black) is for power supply to the host controller (ARIES/LYNX, etc.). Do not supply power to a device with 1A or more.

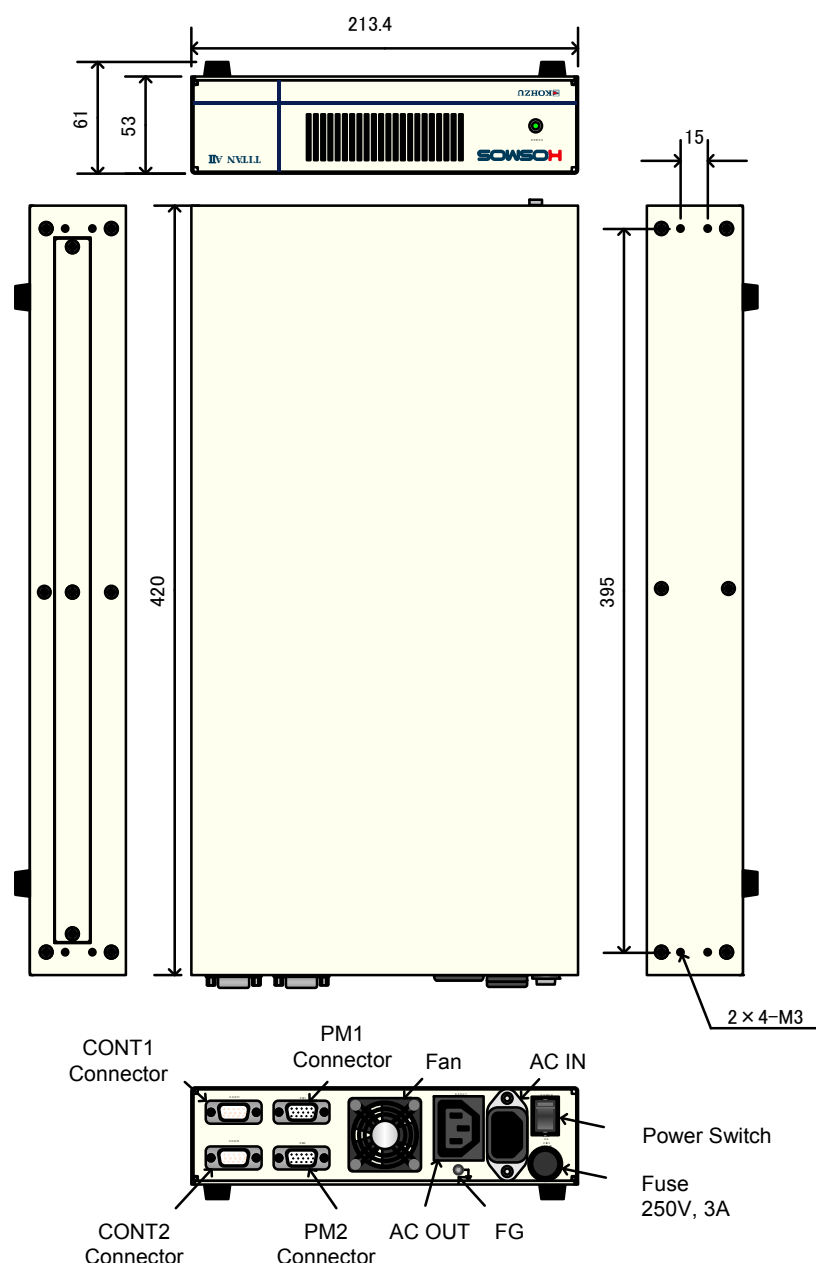

Input/Output Signal

CONT★ Connector
★= Support 1 or 2

Model
Connector: D02-M15PG-N-F0 (JAE)
Connector: D02-22-22P (JAE)
Compatible connector
High density D-sub15 pin female

PM★ Connector
★= Support 1 or 2

Model
Connector: D02-M15SG-N-F0 (JAE)
Connector: D02-22-22S (JAE)
Compatible connector
High density D-sub15 pin male

No.	Signal Name
1	CW+(PULSE+)
2	CW-(PULSE-)
3	CCW+(DIR+)
4	CCW-(DIR-)
5	H.O+
6	H.O-
7	D.S+
8	D.S-
9	EXT_V(*3)
10	NORG
11	CWL
12	CCWL
13	ORG
14	GND(24V)
15	GND(24V)

No.	Signal Name
1	BLU (BLU/BLK)
2	RED (RED/BRN)
3	ORN (ORN/VIO)
4	GRN (GRN/YLW)
5	BLK (WHT/GRY)
6	EXT_V(*3)
7	GND(24V)
8	+24V out(*2)
9	GND(24V)
10	ORG
11	CWL
12	CCWL
13	NORG
14	+24V out(*2)
15	GND(24V)

() is a signal name with 10 leads.

- For CW+,-(PULSE+,-) and CCW+,-(DIR+,-), see "◇ Pulse input method".
- For H.O+,-, see "◎ Hold Off (H.O)".

- *1. Note that the NORG and ORG signals are alternate with the CONT connector and PM connector.
- *2. Pin 8,9,14,15 of the PM* connector supplies 24V as a power supply for the sensors.
- *3. When you use the sensor power supply from a pulse controller, please use EXT_V.

Signal Input/Output Circuit and Connection Diagram

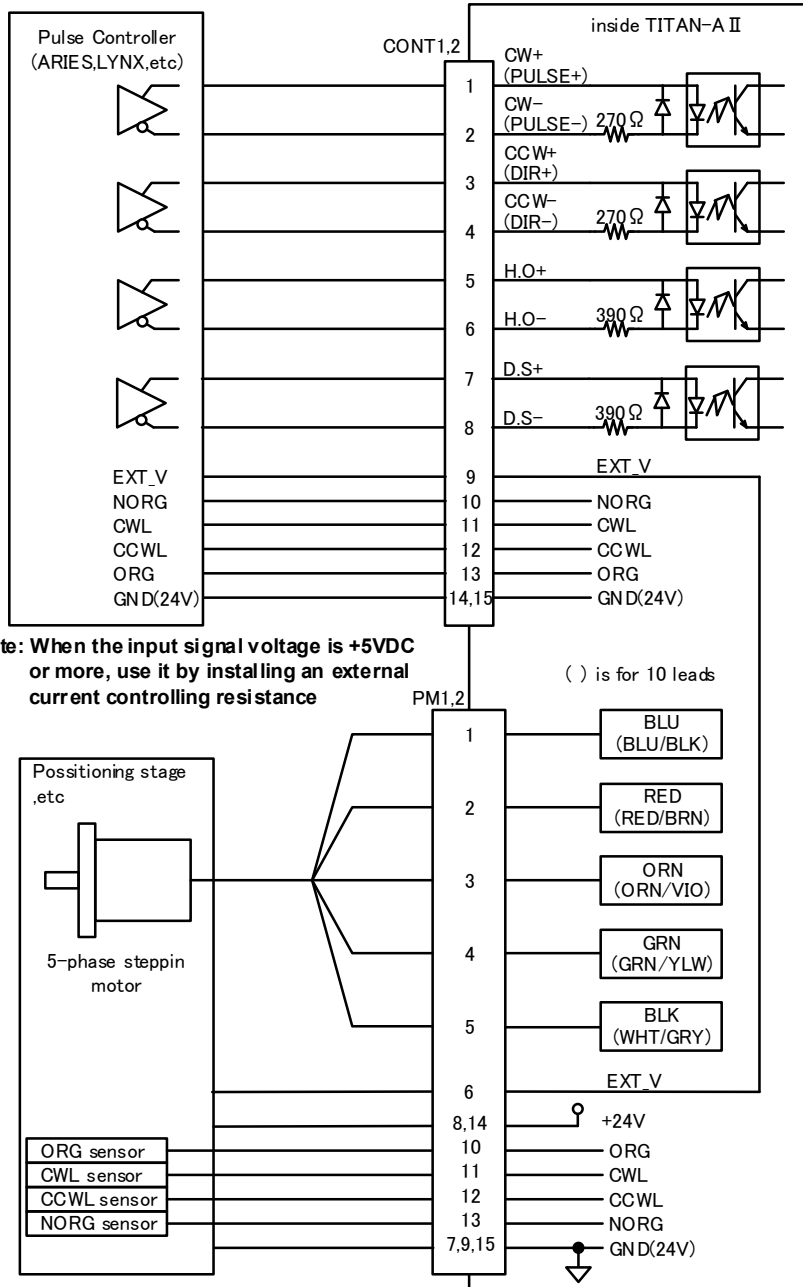

Setting Method for Driver

The aperture plate on the TITAN-A II can be removed (it is fixed in 3 places). The driver setting face as shown in the figure below becomes visible when it is removed.

⚠ When perform driver setting, to prevent electric shock, open the aperture plate after turning the power OFF.

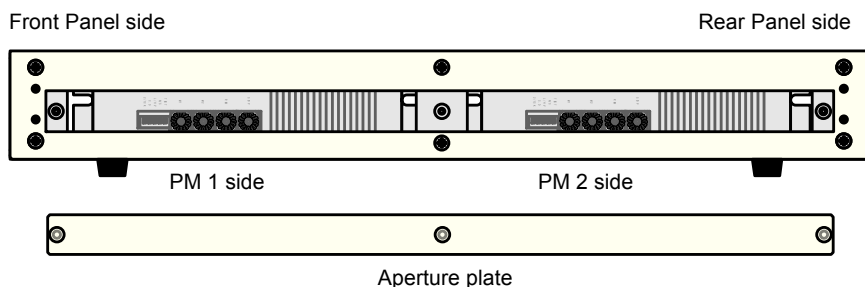

Function Description

◎ Function selector switch

Factory default is 1~4 are OFF, 5 is ON.

Switch	No.	Nameplate display	Function	Switch Position	
				ON	OFF
	1	TEST	Self-diagnostic function	Rotating at 60pps	Normal
	2	CK	Pulse input method	1 pulse input method	2 pulses input method
	3	CD	Automatic current-down	not performed	performed
	4	L/HV	Drive voltage select	Normally OFF	Normal
	5	N/S	Low vibration function	Low vibration	Normal drive

- ◇ Self diagnostic function
 - *Rotate in approx. 60 [pps] regardless of number of divisions.
 - *In the 1 pulse input method, it rotates in CCW, and in the 2 pulses input method, it rotates in CW.
- ◇ Pulse input method
 - *2 pulses method: It controls with CW/CCW signal. Pulse input to CW, and the motor rotates in CW direction. Pulse input to CCW, and the motor rotates in CCW direction. (The logic is high active)
 - *1 pulse method: It controls with PULSE/DIR signal. PULSE is the drive pulse signal input of the motor (the logic is high active), and DIR is the rotation direction signal input of the motor. When the rotation direction signal is [L], it rotates to CCW direction, and when it is [H], the motor rotates to CW direction.
- ◇ Automatic current-down
 - *The function automatically reduces the current while the motor is stopped in the rate set with the STOP current switch to lower heat generation on the motor.
 - *After approx. 150ms from the final pulse input, the current reduces to the stop current set value (STOP).
- ◇ Drive voltage select
 - *It changes the applied voltage to a motor.
 - *The drive voltage is set highly. And high speed, high torque are provided.
- ◇ Low vibration function
 - *When number of divisions setting is 1 or 2, low vibration drive is performed.

Be careful about the heat generation of motor, when using high speed, high torque

◎ Drive current setting (RUN)

Factory default is 5

Switch No	0	1	2	3	4	5	6	7	8	9	A	B	C	D	E	F
Driving current (A/phase)	0.35	0.42	0.50	0.58	0.66	0.75	0.81	0.88	0.96	1.03	1.11	1.18	1.26	1.33	1.40	1.48

- ◇ The drive current is phase current that can be supplied to the 5-phase stepping motor.
- ◇ Depending on the motor's drive frequency, the drive current set value may not be reached.
- ◇ Set the drive current less than the motor's rated current. When it is set exceeding the rated current extremely, heat is generated significantly causing step out and reduced torque.

◎ Stop current setting (STOP)

Factory default is 6

Switch No	0	1	2	3	4	5	6	7	8	9	A	B	C	D	E	F
%	12	19	23	30	37	44	48	55	57	64	68	75	81	87	92	98

- ◇ The stop current is a phase current supplied when the 5-phase stepping motor is stopped.
- ◇ The stop current switch set value is the ratio (%) for the drive current switch setting value.
- ◇ The stop current may have deviation from the motor's winding impedance.
- ◇ This function operates when the CURRENT DOWN switch is OFF. When the switch is ON, the current set in RUN CURRENT for both motor rotation/stop is supplied to the motor.
- ◇ Set the stop current only when the motor is stopped.

◎ Hold Off (H.O)

- ◇ When H.O input is [H], the motor excitation is released, because the supply current to each phase is shutdown.
- ◇ When H.O input [L], it is in the excitation state on the normal motor.
- ◇ Use when manually correct position the motor axis.

◎ Micro-step (M)

Factory default : M1 is 1, M2 is 6

Switch No	0	1	2	3	4	5	6	7	8	9	A	B	C	D	E	F
Number of divisions	1	2	4	5	8	10	20	40	80	16	25	50	100	125	200	250

- ◇ Number of divisions setting (M1, M2)
- *Drive the motor by dividing the basic angle (0.72°) on the 5-phase stepping motor with the setting value.
- *Divided step angle is obtained with the following formula.

$$\text{Motor 1 Step angle} = \frac{\text{Basic angle (0.72°)}}{\text{Number of divisions}}$$

*When the number of divisions is changed during driving, the motor step out may happen.

- ◇ Change of number of divisions setting (Change of step angle)

- *Setting of M1 or the M2 is chosen by a voltage level input into DS
- *When D.S input is [L], Number of divisions set in M1 is chosen.
- When D.S input is [H], Number of divisions set in M2 is chosen.

- *Perform the change of the number of divisions at the time of the stop of the motor. When a change of the number of divisions is carried out during drive, the step out of the motor may occur.
- When changing step angle by a DS signal, wait for more than 1 msec until it drives.
- *The phase of the motor excitation cannot change by ON/OFF of the DS signal.

Time Chart

◎ CW and CCW input

(CW: Clockwise direction viewed from the motor axis side)

- ◇ 2 pulses input method

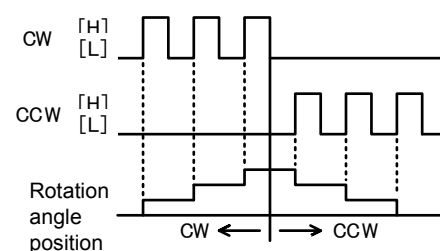

- ◇ 1 pulse input method

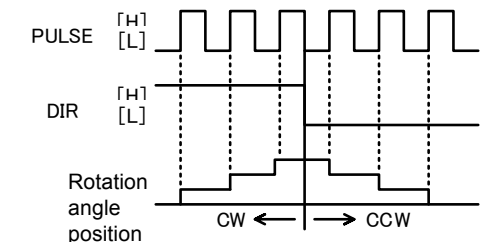

■ Connection Diagram

The connection diagram of TITAN with the configuration of our company's product is shown below. (The interface in TITAN-A II and TITAN-D II are identical).

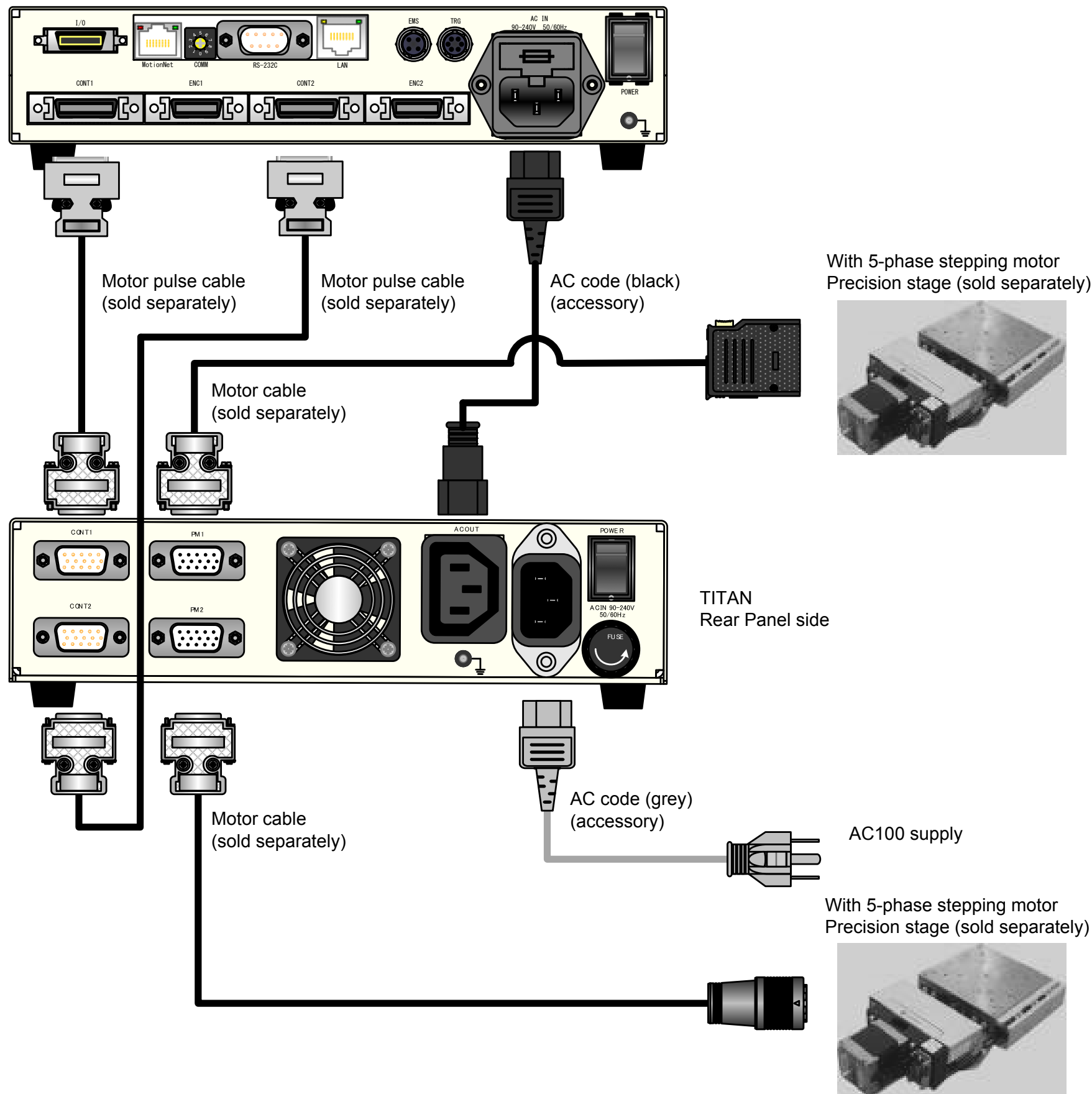

■ Trouble Diagnostics and Measures

- The motor does not rotate.
 - Check the controller, connection condition of TITAN, and pulse input specification (voltage and width).
 - Check the input pulse method and connection condition.
 - For the 1 pulse input method, check if the pulse and direction signal are connected correctly.
- The motor rotates in the reverse direction from the specified direction.
 - For the 2 pulses input method, check if the input pulse of the CW signal and CCW signal is connected correctly.
 - For the 1 pulse input method, check the DIR signal level. When the input is [H], it is a regular rotation, for [L], it is a reverse rotation.
- The motor operation is unstable.
 - Check the connection between TITAN and the motor is correct.
 - Check the pulse input specification (voltage and width) to TITAN.
 - Check if the drive current with the drive current setting (RUN) is equivalent to the phase current of the motor rating.
 - Apply the power after 15 seconds or more from the power shutdown.

■ Precautions for Use

- Precautions for signal input
 - Do not input CW and CCW simultaneously with the 2 pulses input method. It causes abnormal operation. When other signal is input while either the CW and CCW signal is [H], it may not operate correctly.
 - When the signal input voltage is larger than the voltage specified in the specification, make sure to connect additional resistance from outside.
- Precautions for connection
 - For a signal wire, use a twist pair wire (0.08mm² or more).
- Precautions for function selector switch
 - Before turning the power ON, check if the self-diagnostic function switch is OFF. If power and signal are applied while it is set to ON, be careful since the motor operates suddenly.
 - If the input signal method selector switch is changed to the 2 pulses input method while driving with the 1 pulse input method, it results in abnormal operation. Do not change the input signal during motor driving.

***If "Precautions for Use" above are not observed correctly, it may damage the product. Make sure to follow the contents described in the section for safe operation.**



2-6-15 Kurigi Aso-ku Kawasaki City, Kanagawa
Japan 215-8521

Tel : +81-44-981-2131

Fax : +81-44-981-2181

Email : sale@kohzu.co.jp

Web :

<http://www.kohzuprecision.com>